

PAY LIMITS FOR CURB RAMP

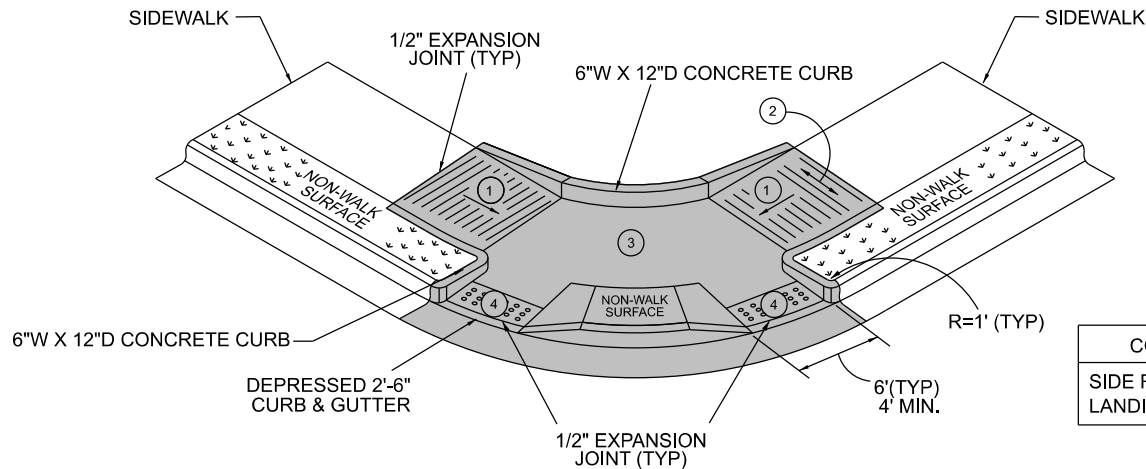

CONCRETE DEPTH	
SIDE RAMPS	4"
LANDING & OPENINGS	6"

TYPE R-3

1. 8.33% (12:1) MAX RAMP SLOPE
2. CROSS SLOPE: 2.00%
3. CURB RAMPS REQUIRE A (4'-0") MINIMUM LANDING WITH A MAXIMUM CROSS SLOPE AND LONGITUDINAL SLOPE OF 2.00% WHERE PEDESTRIANS PERFORM TURNING MANEUVERS. SLOPE TO DRAIN TO CURB.
4. RAMPS AND DOMES SHALL BE INSTALLED THE SAME WIDTH AS THE SIDEWALK.

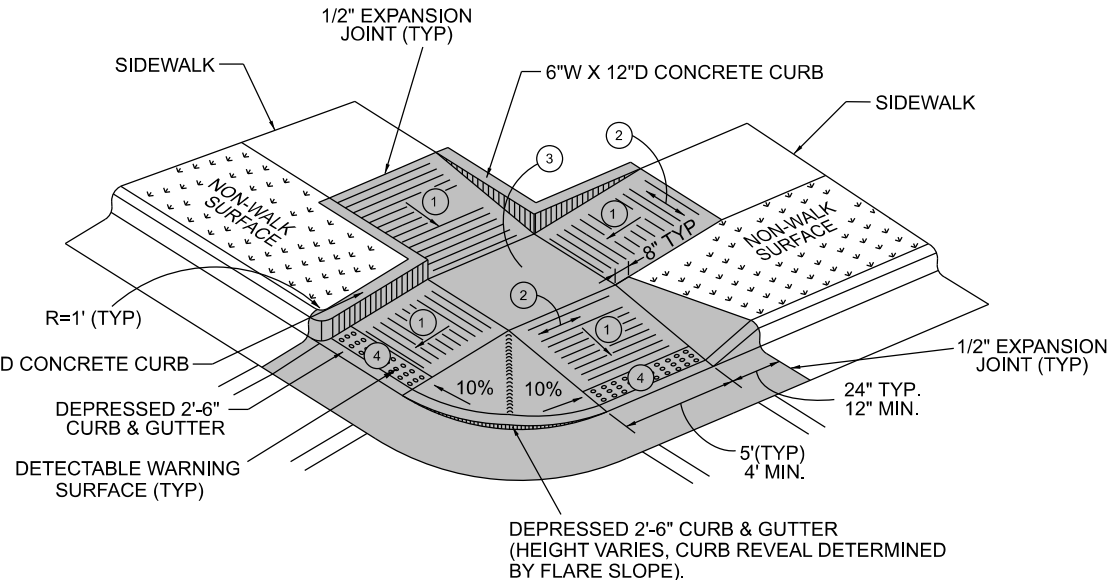

CONCRETE DEPTH	
SIDE RAMPS	4"
LANDING & CURB RAMPS	6"

TYPE R-4

CURB RAMPS - RETROFIT

DESIGNED BY:	TOG	REVISED	FEB. 2022
APPROVED BY:	CSJ	STD. NO.	T-2.01.6

TOWN OF GARNER, N.C.

