

PLAN

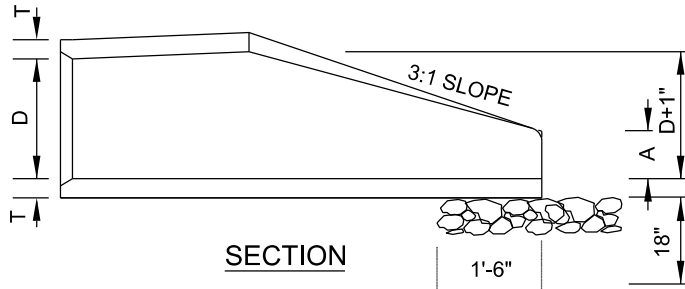

SECTION

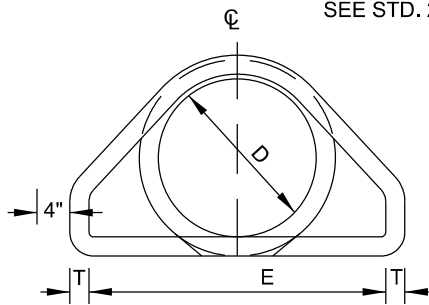

END VIEW

TABLE OF DIMENSIONS							
D	T	A	B	C	E	L	WT.
12"	2-1/4"	4"	2'-0"	4'-1"	2'-0"	6'-1"	730
15"	2-1/4"	6"	2'-3"	3'-10"	2'-0"	6'-1"	730
18"	2-1/2"	9"	2'-3"	3'-10"	3'-0"	6'-1"	1190
24"	3"	10"	3'-8"	2'-6"	4'-0"	6'-2"	1770
30"	3-1/2"	1'-0"	4'-6"	1'-8"	5'-0"	6'-2"	2380
36"	4"	1'-3"	5'-3"	2'-11"	6'-0"	8'-2"	5320
42"	4-1/2"	1'-9"	5'-3"	2'-11"	6'-6"	8'-2"	5920
48"	5"	2'-0"	6'-0"	2'-2"	7'-0"	8'-2"	7470
54"	5-1/2"	2'-3"	5'-6"	2'-10"	7'-6"	8'-4"	8810
60"	6"	2'-6"	5'-0"	3'-3"	8'-0"	8'-3"	11180
66"	6-1/2"	3'-0"	6'-0"	2'-3"	8'-6"	8'-3"	12530
72"	7"	3'-0"	6'-6"	1'-9"	9'-0"	8'-3"	13980

NOTES:

1. SEE FORMER NCDOT STANDARD 310.01 FOR DETAILS.
2. REINFORCEMENT SHALL CONFORM TO THE REQUIREMENTS OF REINFORCED CONCRETE PIPE OF LIKE DIAMETER PER AASHTO M170, TABLE 2, WALL B.
3. ALL CONCRETE TO BE 3600 PSI COMPRESSIVE STRENGTH.
4. PROVIDE TONGUE OR SPIGOT JOINT AT INLET END SECTION.
5. PROVIDE GROOVE OR BELL JOINT AT OUTLET END SECTION.
6. THE DIMENSIONS FOR END SECTIONS SHALL SUBSTANTIALLY AGREE WITH THE TABLE. MINOR VARIATIONS WILL BE PERMITTED BASED ON THE MANUFACTURER'S STANDARD FORMS AND TEMPLATES.
7. NOT TO BE USED IN NCDOT MAINTAINED RIGHT OF WAY.

NOT TO SCALE



FLARED END SECTION (12" THRU 72" PIPE)

TOWN OF GARNER, N.C.

DESIGNED BY:

TOG

REVISED
FEB. 2022

APPROVED BY:

CSJ

STD. NO.
SW-3.04