

* SEE NOTE #6

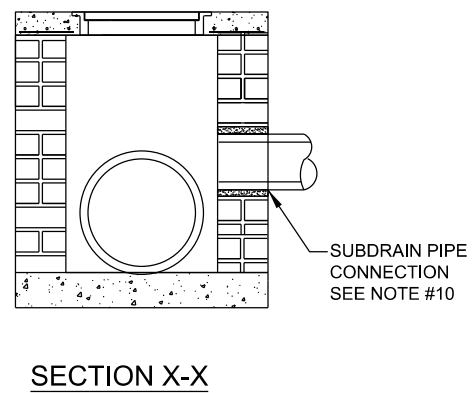
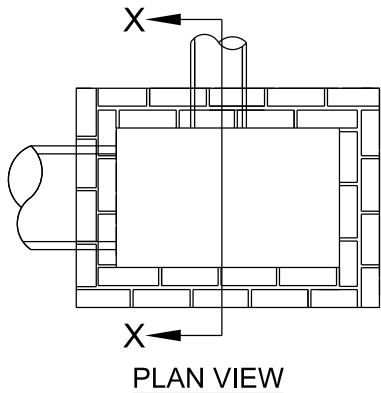

CONNECTION AT DRAINAGE STRUCTURE

NOTE: STRUCTURE SHOWN FOR REPRESENTATION PURPOSES ONLY.

NOTES:

1. A MINIMUM OF 6" FROM OUTSIDE DIAMETER OF PIPE TO SIDE OF TRENCH MUST BE ALLOWED FOR WASHED STONE. THE METHOD OF COMPACTING BACKFILL MATERIAL IS SUBJECT TO APPROVAL BY THE CITY ENGINEER. AN APPROVED FILTER FABRIC SHALL BE PLACED AROUND STONE AND OVERLAPPED 8" AT TOP WITHIN STREET RIGHT OF WAY.
2. SUBDRAIN IS TO BE A MINIMUM 6" DIAMETER PERFORATED PIPE; USE SCHEDULE 40 PVC PER ASTM D1785 OR HDPE PER AASHTO M252, TYPE CP (SINGLE-WALL, CORRUGATED) OR TYPE SP (DOUBLE-WALL, SMOOTH INTERIOR).
3. OUTLET PIPE FROM SUBDRAIN SHALL BE NON-PERFORATED UNDER PAVEMENT (INCLUDING SIDEWALKS AND DRIVEWAYS). SEE SITE PLAN FOR SLOPE OF SUBDRAIN AND TIE IN TO STORM DRAINAGE.
4. THE OUTLET PIPES SHALL BE SCHEDULE 40 (MIN.) PVC PER ASTM D2665 OR HDPE PER AASHTO M252, TYPE S (DOUBLE WALL, SMOOTH INTERIOR) UNDER ROADWAYS.
5. FILTER FABRIC SHALL BE AN APPROVED, TYPE 2 WATER PERMEABLE, SYNTHETIC FABRIC.
6. A MINIMUM 4" DIAMETER SUBDRAIN MAY BE USED IN PLANTING AREAS AS DESCRIBED IN THE CLDSM 4000 SERIES.
7. CLEAN-OUTS ARE RECOMMENDED AT ALL PIPE INTERSECTIONS AND AT A 100' MAXIMUM SEPARATION.
8. SUBDRAIN INVERTS AT CATCH BASINS SHOULD BE INSTALLED ABOVE THE BOTTOM TO AVOID SURCHARGE OF SUBDRAIN SYSTEM.
9. ALL SUBDRAINS WILL TIE INTO A STANDARD DRAINAGE STRUCTURE OR DAYLIGHT TO THE SURFACE WHERE APPROPRIATE, AND NOT DIRECTLY INTO A PIPE.
10. ONLY REMOVE NECESSARY MASONRY UNITS TO INSTALL PIPE INTO BASIN WALL. PRECAST STRUCTURES WILL BE CORE DRILLED 2 INCHES LARGER THAN PIPE DIAMETER TO PROVIDE FOR INSTALLATION OF PIPE IN WALL.
11. ALL PIPE IN STORM DRAIN STRUCTURE SHALL BE STRUCK EVEN WITH THE INSIDE WALL, GROUTED AND BRUSHED SMOOTH.
12. PIPE INSTALLATION PER SECTION 300 NCDOT STANDARD SPECIFICATIONS FOR ROADS AND STRUCTURES.
13. SUBDRAINS WILL BE INSTALLED AT A DRAINAGE STRUCTURE AND THIS CONNECTION WILL NEED TO BE INSPECTED BY CITY STAFF PRIOR TO BACKFILLING.
14. SCHEDULE 40 PVC (NON-PERFORATED) SHALL BE USED TO MAKE THE CONNECTION TO THE STORM DRAINAGE SYSTEM. CONNECTION WILL BE WITHIN THE RIGHT-OF-WAY UNLESS OTHERWISE APPROVED BY THE CITY ENGINEER.
15. PREFABRICATED DRAINAGE MAY BE USED WITH APPROVAL OF CITY ENGINEER
16. MAXIMUM OF TWO SUBDRAIN PENETRATIONS PER WALL OF DRAINAGE STRUCTURE.



SUBDRAIN DETAIL

TOWN OF GARNER, N.C.

DESIGNED BY:	TOG	REVISED
		FEB. 2022
APPROVED BY:	CSJ	STD. NO.
		SW-1.05